



## FLOW SERIES

ONE-STOP SOLUTION

ONE-STOP SERVICE

# ULTRASONIC FLOW METER

# UF2000-B Wall Mounted Ultrasonic Flowmeter

## Profiles



The UF2000-B flowmeter is designed for versatile application in long-term online measurements. It boasts an IP67 rated converter and an IP68 rated transducer, ensuring durability. It accommodates a diverse range of liquid applications, including ultra-pure liquids, portable water, chemicals, raw sewage, reclaimed water, cooling water, river water, plant effluent, and more.

## Features

- High measurement accuracy of 1%.
- A robust design with IP67 converter and IP68 transducers.
- Wide measurement range, accommodating pipe sizes from DN15mm to DN6000mm.
- Flexible with three installation methods: wall mounted, DIN-rail mounted, and explosion-proof box mounted.
- Heat/energy measurement supported by connecting the temperature transducer.

## Dimensions

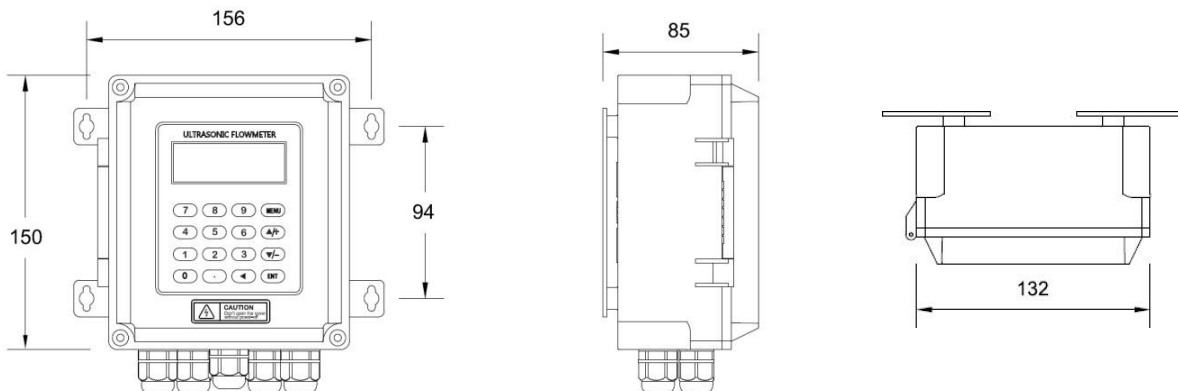

Measuring Diagram

Flow Measurement

Heat Measurement

Features

Clamp on



- ◆ No need to cut off pipes and no pressure loss.
- ◆ Temperature transducers supported for heat/energy measurement.
- ◆ Easy to install.

Insertion



- ◆ No need to cut off pipes and no pressure loss.
- ◆ PT100 temperature transducers connecting for heat/energy measurement.
- ◆ Stable and reliable for long term operation









Pipe cutoff







- ◆ Pipe cutoff required and no pressure loss.
- ◆ PT100 temperature transducers connecting for heat/energy measurement.
- ◆ High accuracy and stability.

### Optional Transducers

Please choose the suitable transducer, according to different pipe condition and installation method, (please refer to the measuring diagram).

Types	Picture	Spec.	Model	Measurement Range	Temperature	Dimension	
Clamp on		Small Size	TS-2	DN32-65	-30-90°C	45x25x32mm	
		Medium Size	TM-1	DN80-400	-30-90°C	64x39x44mm	
		Large Size	TL-1	DN450-1000	-30-90°C	97x54x53mm	
High temp clamp on		Small Size	TS-2-HT	DN32-65	-30-160°C	45x25x32mm	
		Medium Size	TM-1-HT	DN80-400	-30-160°C	64x39x44mm	
		Large Size	TL-1-HT	DN450-1000	-30-160°C	97x54x53mm	
Insertion		Standard	TC-1	DN80-6000	-30-160°C	190x80x55mm	
		Lengthen	TC-2			335x80x55mm	
		Parallel	TP-1	DN200-6000		300x80x55mm	
Pipe		Type	G1	DN15-DN32	-30-160°C	SUS304 threaded	Please refer to detailed pipe dimensions
		Standard	G2	DN40-DN1000	-30-160°C	Carbon steel threaded	

### Optional Transducers

Picture	Specification	Model	Meas. Range	Temperature	Cut off water	Accuracy
	Clamp on temp. transducer Pt100	CT-1	>DN50	-40-160°C	No	100°C ± 0.8°C
	Insertion temp. transducer PM 00	TCT-1	>DN50	-40-160°C	Yes	
	Insertion Pt100 installation with pressure	PCT-1	>DN50	-40-160°C	No	
	Insertion Pt100 Small size pipe diameter	SCT-1	<DN50	-40-160°C	Yes	

### Optional SD card memory

Convenient for long-term and large data storage. Data processing like tabulation, statistical, data analysis, printing reports and production flow curve are available by using data analysis software.



Technical Parameters

Items	Parameter	
Host	Principle	Transit- time ultrasonic flow meter
	Accuracy	±1%
	Display	2X20 character LCD with backlight, support Chinese, English and Italy languages
	Signal Output	1 way 4~20mA output, electric resistance 0~ 1K, accuracy 0. 1%(optional)
		1 way OCT pulse output(Pulse width 6~1000ms, default is 200ms)
		1 way Relay output
	Signal Output	3 way 4~20mA input, accuracy 0. 1%, acquisition signal such as temperature, press and liquid level
Connect the temperature transducer Pt100, can finish the heat/energy measurement		
Data Interface	Insulate Rs485 serial interface, upgrade the flow meter software by computer, support the MODBUS	
Special Cable	Twisted-pair cable, generally, the length under 50 meters ; Select the RS485, transmission distance can over 1000m	
Pipe Installation Condition	Pipe Material	Steel, Stainless steel, Cast iron, Copper, Cement pipe, PVC, Aluminum, Glass steel product, liner is allowed
	Pipe Diameter	DN32~6000mm
	Straight Pipe	Transducer installation should be satisfied: upstream10D, downstream 5D, 30D from the pump
Work environment	Protection grade	Host:IP67; flow sensor:IP68
	temperature	Host:-20~60 ; flow sensor:-30~ 160
	Humidity	Host: 85%RH; Flow sensor can measure under water, water depth^2m (transducer sealed glue)
Power Supply	DC8~36V or AC85~264V	
Power Consumption	1.5W	
Frequency	0.5MHz	
Repeatability	0.2%	

Order Information

**UF2000B**

**SELECTION Type**

**2**

**100**

**0**

**5**

**1**

**0**

Flow Transducer  
 1=TS-2      2=TM-1  
 3=TL-1      4=TS-2-HT  
 5=TM-1-HT   6=TL-1-HT  
 7=TC-1 (Refer To Optional  
 Transducers Table)

DN Size  
 25 = DN25mm      50 = DN 50mm  
 80 = DN 80mm      100 = DN100mm  
 150 = DN150      .....  
 6000= DN6000mm

Pipe Material  
 0= Carbon Steel      1 = Stainless Steel  
 2 = Cast Iron      3 = Glass Fiber reinforced  
 4= PVC      5 = Cement      6 = Others

Cable Length  
 5= 5m  
 .....  
 10 = 10m

Temperature Transducer  
 1=None      2=CT-1      3=TCT-1      4=PCT-1  
 5=SCT-1(Refer To the Optional Temperature Transducers Table)

SD card Memory  
 0=Yes      1=No